

KOSHO

“Build your own Sukkah!”

This simple statement led us to the development of *KOSHO* - our design proposal - and persuaded us to build a 1:1 scale prototype to test its feasibility. Thanks to this experience we are not only skilled at building a second *KOSHO* in NYC, but also willing to share our knowledge and every necessary detail to make anyone else able to *do the same at home*.

As a consequence we decided that the best way to present *KOSHO* to the Competition Jury and to the Citizens of

New York was to tell the story of how it was built once upon a time, in a hypothetical place, by three imaginary boys. The star of David – superimposition of two equilateral triangles - is the generative image of our Sukkah. The octahedron - polyhedron with eight triangular faces – is the three-dimensional materialization of our construction. A wooden fan is the triggering metaphor of our tectonic principle. *KOSHO* is a simple, light, transportable, low-cost, *kosher* construction that meets the rules

and regulations listed in the competition brief. *KOSHO* is small but comfortable, can be easily transported, quickly installed and dismantled. *KOSHO* is a symmetrical polyhedron built through the juxtaposition of modular elements, but when perceived from different angles and in diverse light conditions, it appears as a dynamic and articulated structure. As the eye moves around, a multitude of slanting trajectories between the earth and the sky reveals the essence and the meaning of the construction.

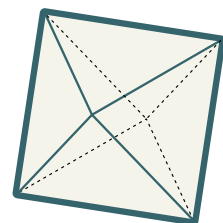
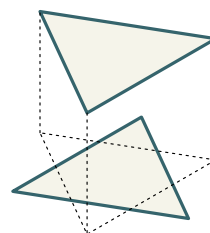
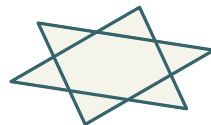

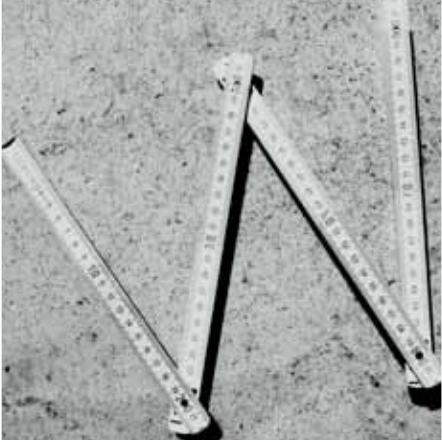
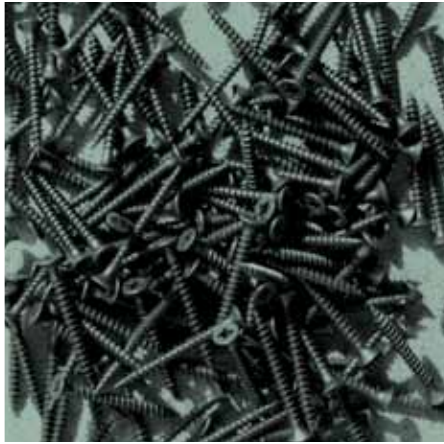
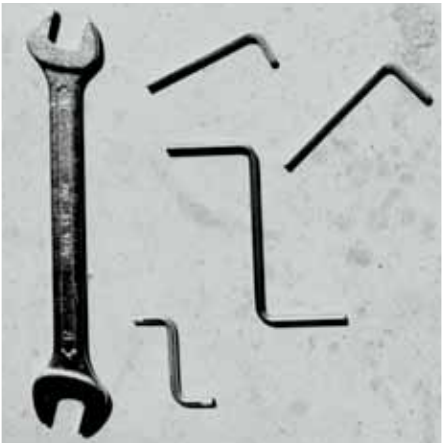
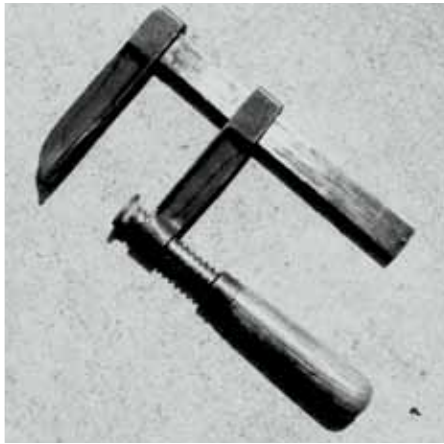
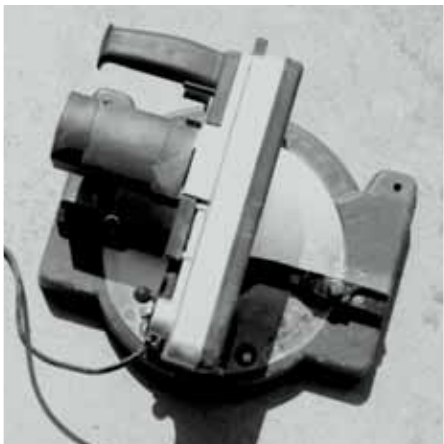
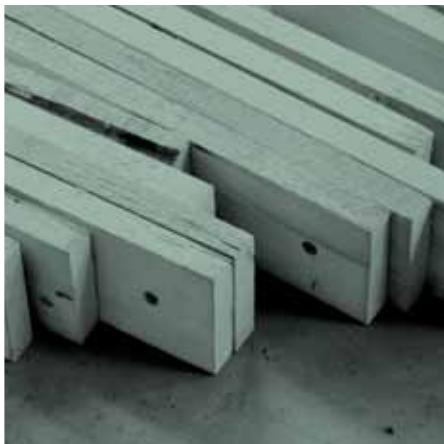

Tools

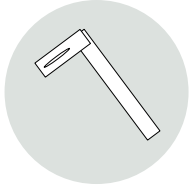

carpenter's square

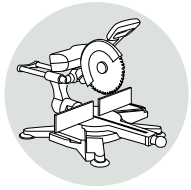

miter saw

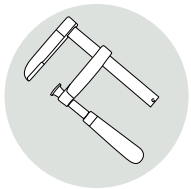

clamps

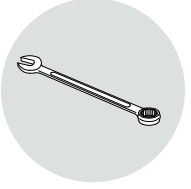

wrenches

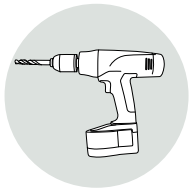

drill

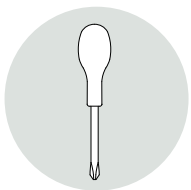

screwdrivers



hammer

Components

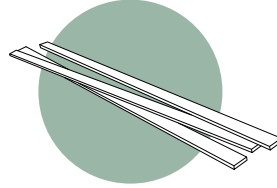

60 X fir planks $\frac{3}{4}$ " x 3 $\frac{1}{2}$ " x 10 ft

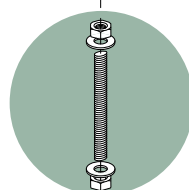

6 X 1 ft $\frac{1}{2}$ " threaded rod
12 X $\frac{1}{2}$ " nuts and washers

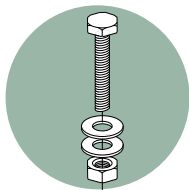

12 X $\frac{3}{8}$ " bolts
12 X $\frac{3}{8}$ " nuts
24 X $\frac{3}{8}$ " washers

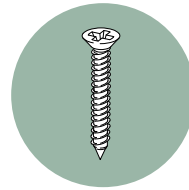

120 X $\frac{5}{32}$ ", 1 $\frac{3}{4}$ " length
countersunk head timber
screws

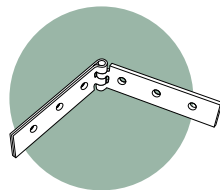

24 X 9" wide hinges

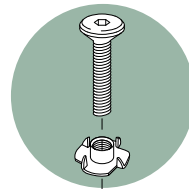

96 X $\frac{1}{4}$ " screws
96 X $\frac{1}{4}$ " threaded inserts for wood

Operations

Step 1

Mark the wooden planks from 1 to 10, locate the exact position on the planks ends and drill holes with a driller.

Step 2

Slot planks from 1 to 9 into the $\frac{1}{2}$ " threaded rod, place a $\frac{1}{2}$ " washer and a $\frac{1}{2}$ " nuts on each end of the rod.

Step 3

Spread out the joined planks and connect plank 10 with planks 8 and 9 with $\frac{3}{8}$ " bolts, nuts and washers.

Step 4

Carefully position planks from 1 to 7 along plank 10, mark with a pencil their excess portions.

Step 5

Dismantle everything and cut the excess portions of planks from 1 to 7 with a miter saw.

Step 6

Now that you have the 10 planks templates, you are ready to build the six triangles you need. If you need to transport your *KOSHO* and install it somewhere else leave the 6 sets closed in bundles, if you are already working in your garden spread out the joined planks, re-position planks from 1 to 7 and screw them on planks 10.

Step 7

Lay down your 6 triangles, position the hinges along planks 8 and 9 of each triangle and fix them with $\frac{1}{4}$ " screws and $\frac{1}{4}$ " threaded inserts for wood.

Step 8

Once you have completed the first 7 steps and laid out your *KOSHO* on the floor as in the unfolded plan, you are ready to go! You might need some ropes to prop the structure as you fold up and join together the different faces of the polyhedron. A ladder is necessary only if you are less than 6 ft tall.

Step 9

Once your *KOSHO* is properly assembled and fastened you should be able to roll it on the ground to reach the exact position to enjoy it.

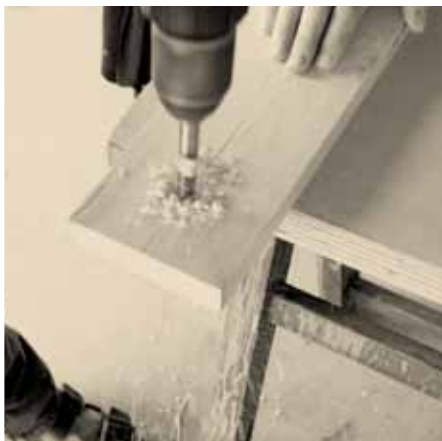
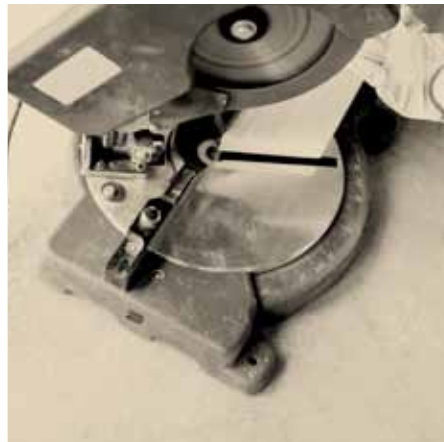
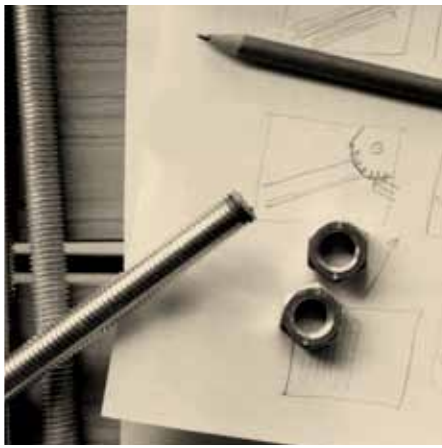

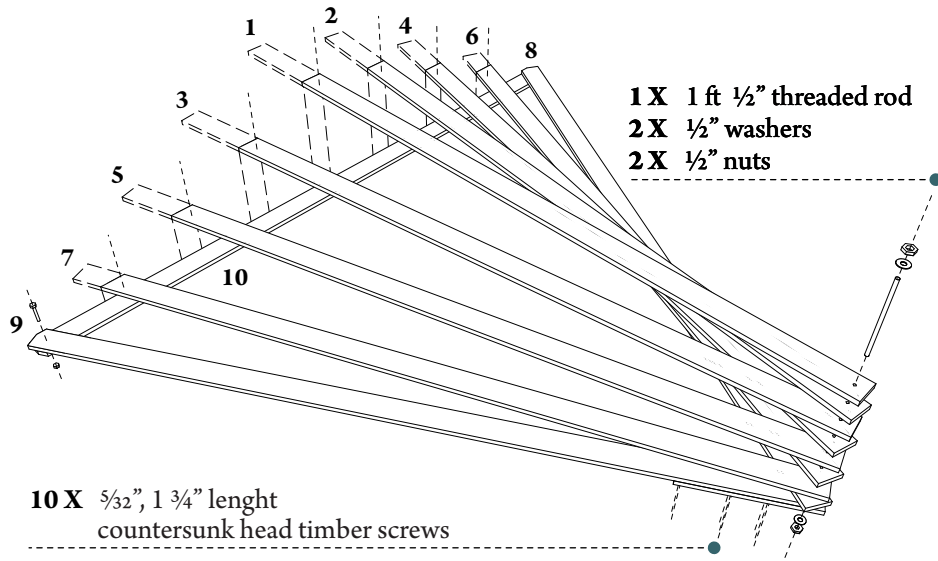

The structure is composed by six triangles. The triangle is a crushproof shape. Thus, the walls remain unshaken by a steady wind

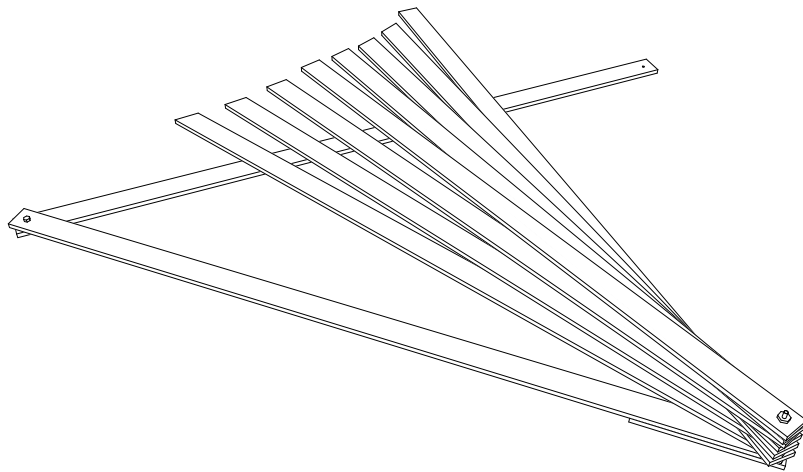
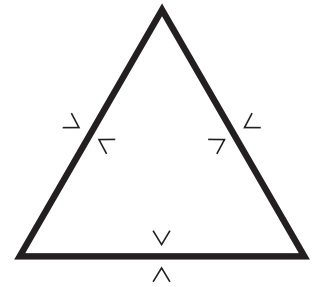

A wooden fan is the triggering metaphor of the tectonic principle. 6 fan-like triangles are the basic modular elements of the construction

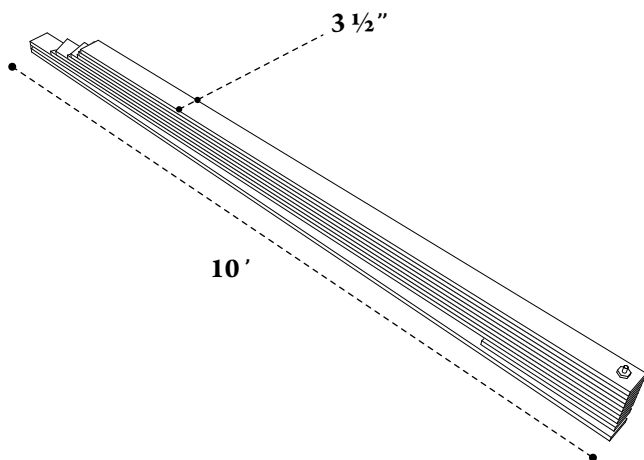
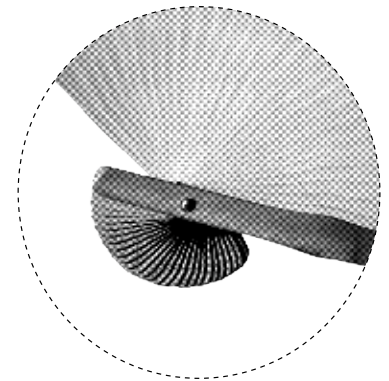

The 6 sets of planks can be easily folded and closed in bundles. Each set weights only 66 lb and can be comfortably transported by two persons



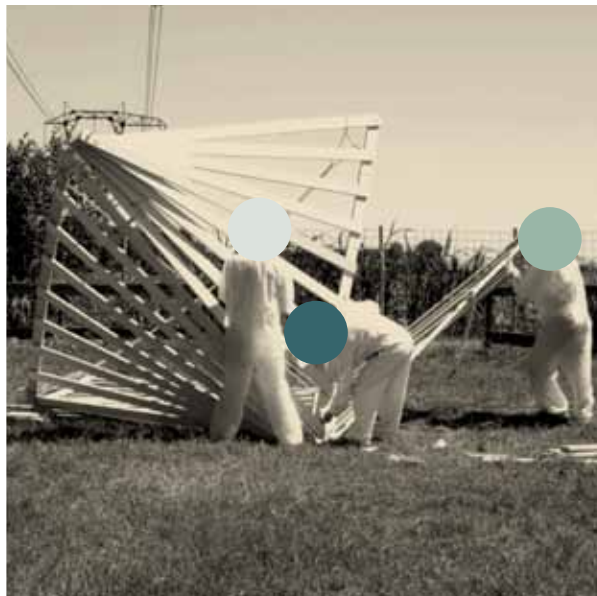
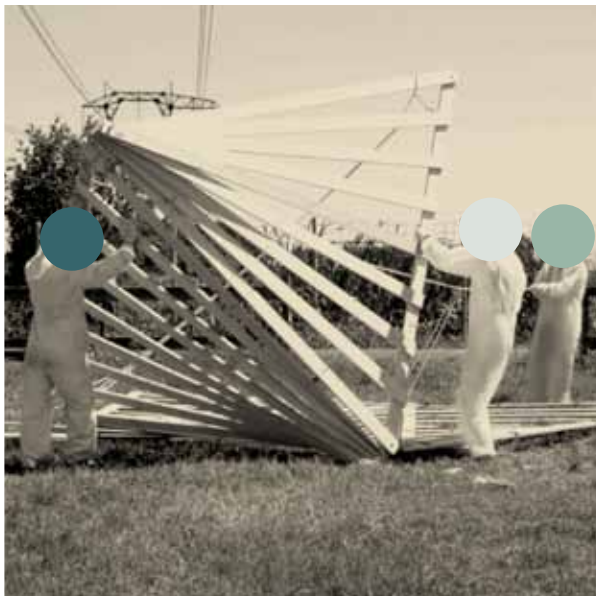
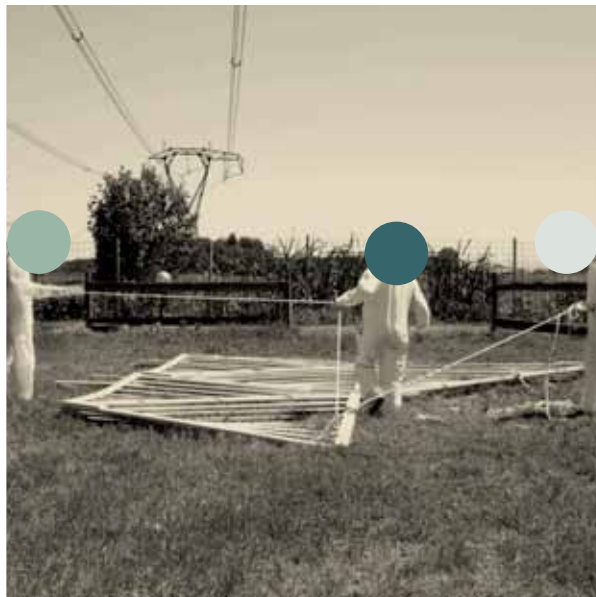
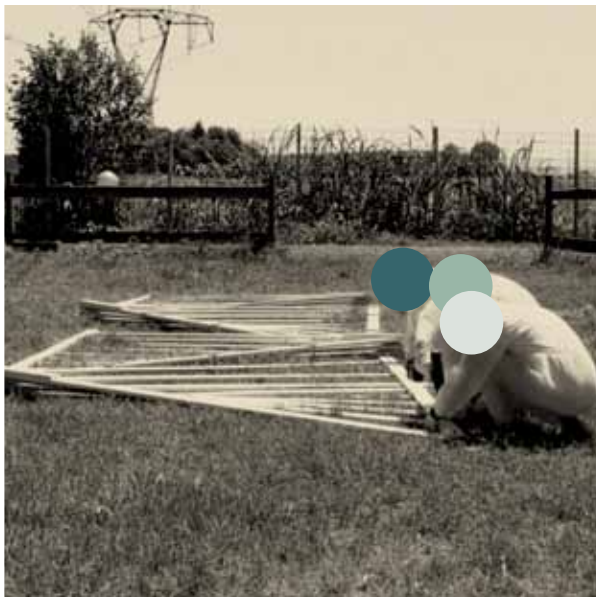
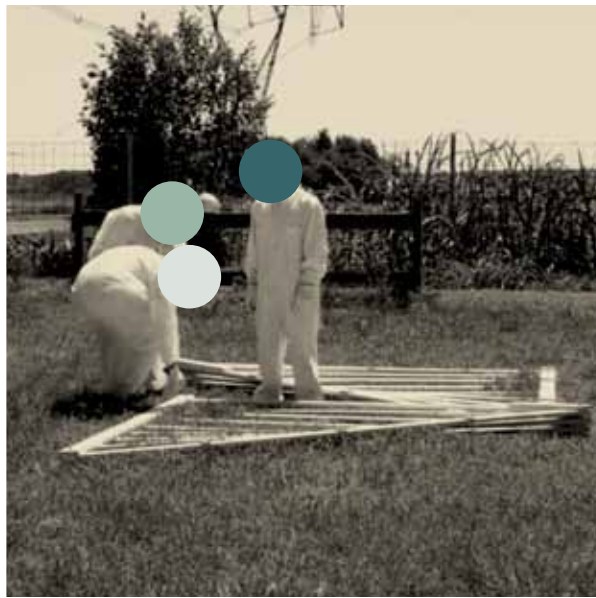
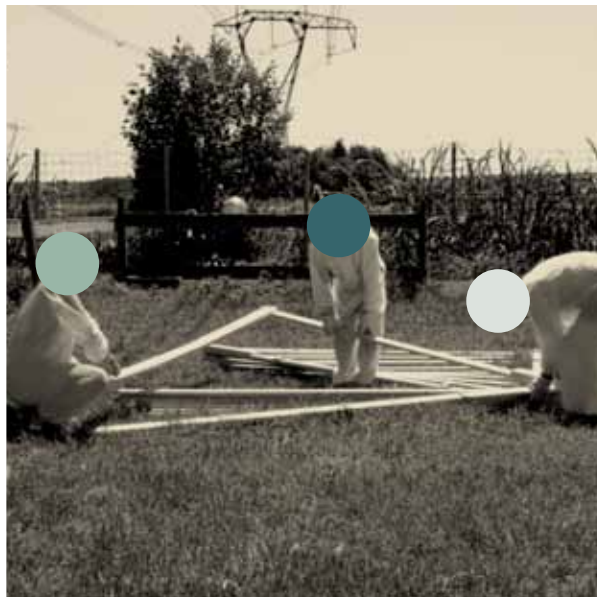
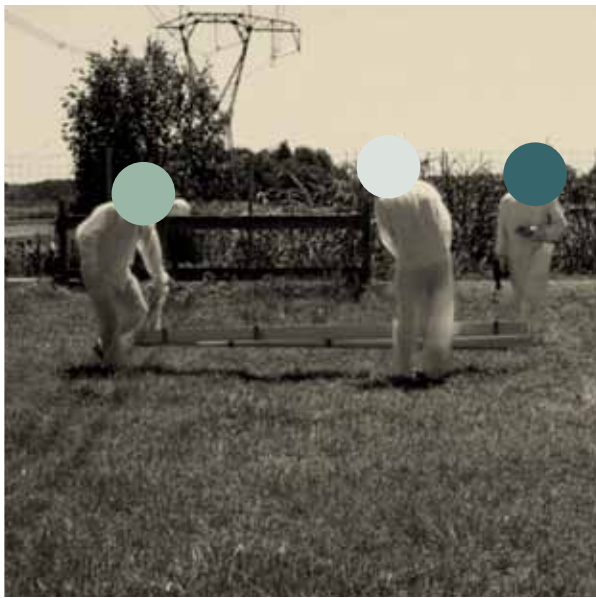

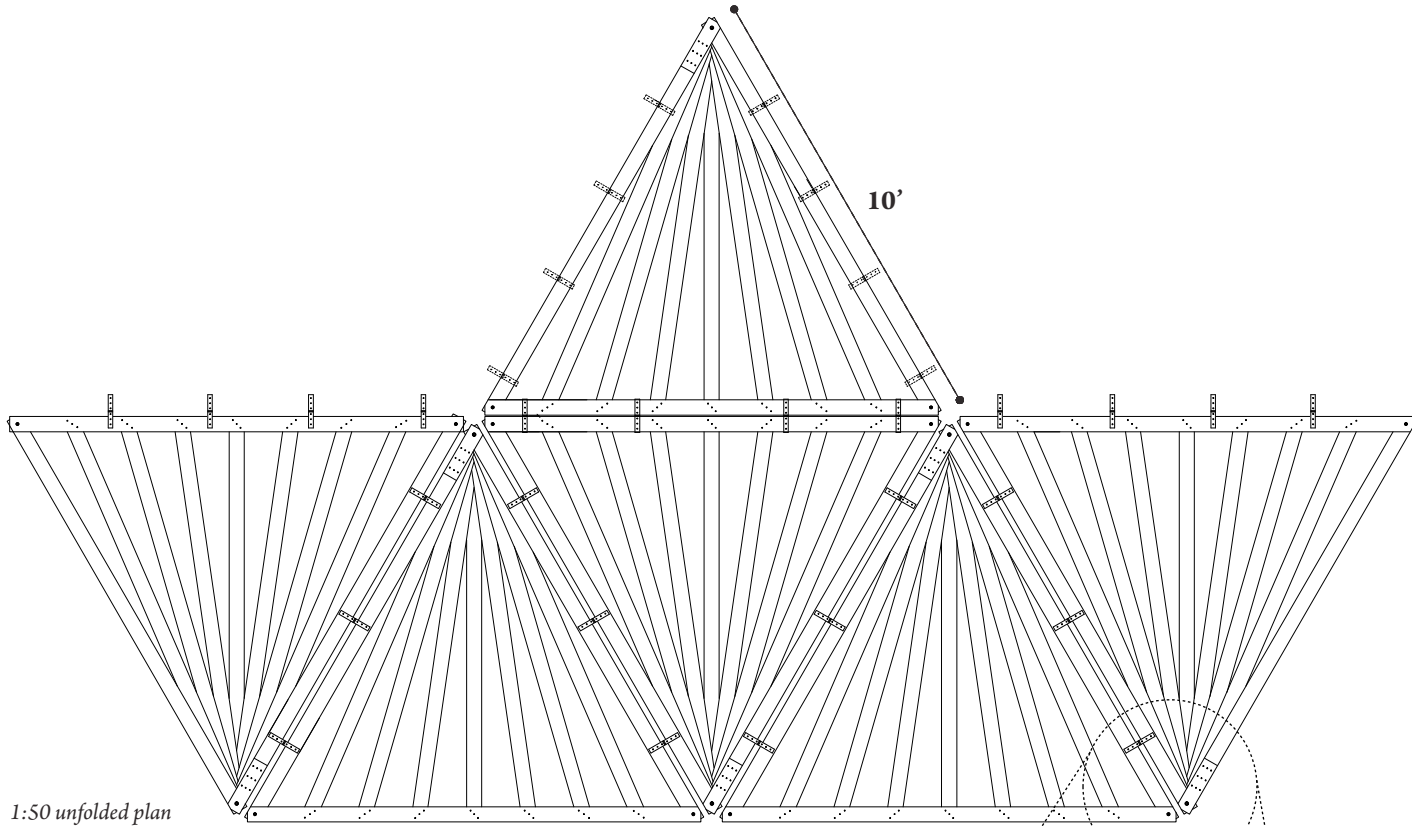
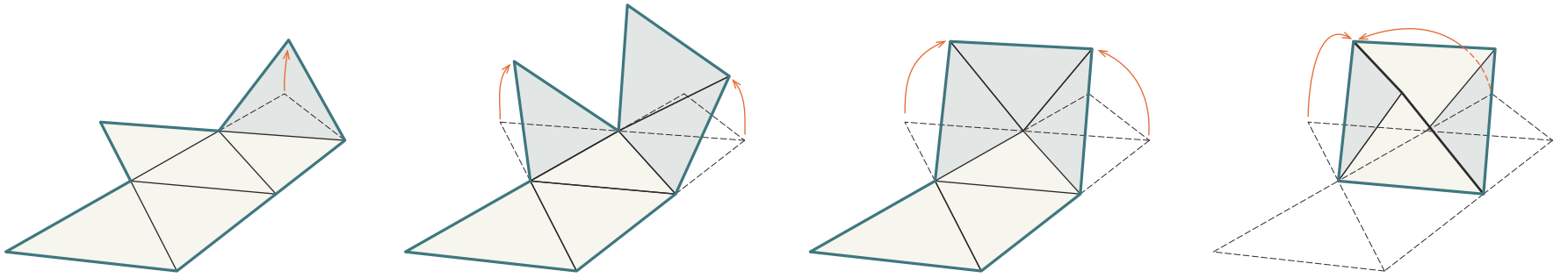

1:50 unfolded plan

- 1 X** 9" wide hinge
- 6 X** 1/4" threaded inserts for wood
- 6 X** 1/4" screws
- 9 X** 5/32", 1 3/4" length
countersunk head timber screws
- 1 X** 1 ft 1/2" threaded rod
- 2 X** 1/2" washers
- 2 X** 1/2" nuts

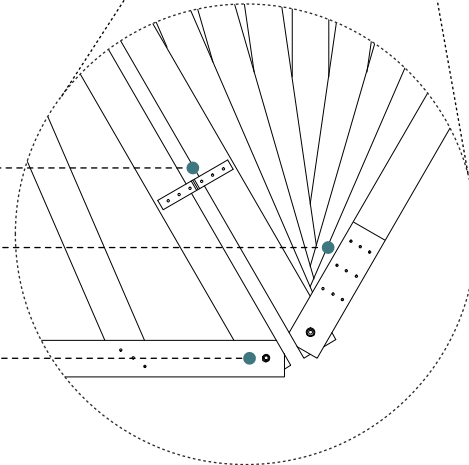

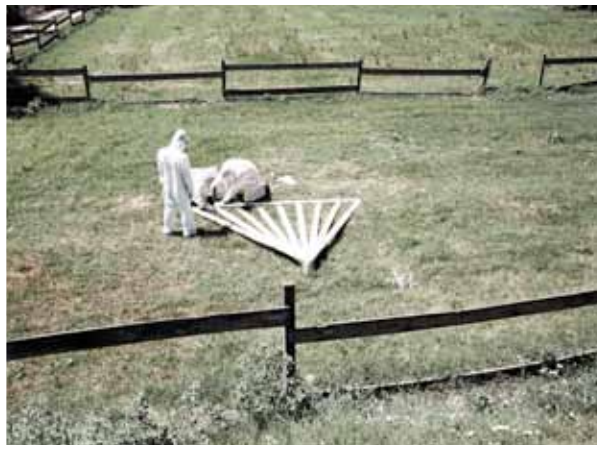

KOSHO is kosher...

side view

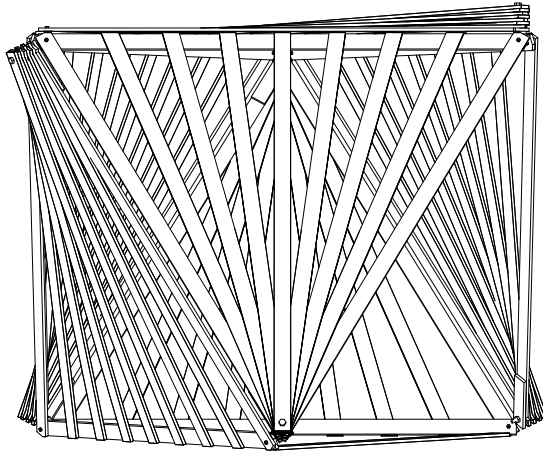

side view

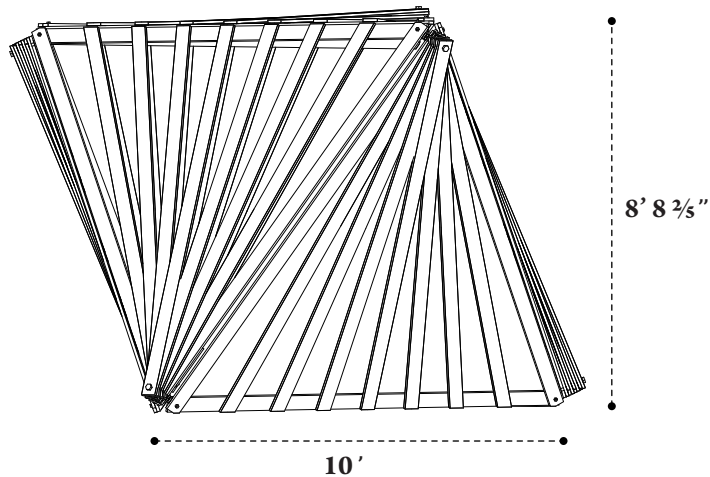

top view

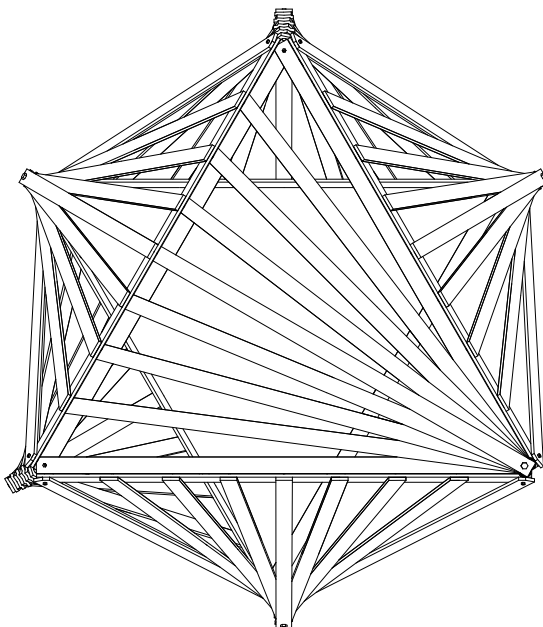

A whale or a living elephant might be used instead of one of *KOSHO's* triangular walls

The floor area is 42 square feet, which is bigger than 7 x 7 square handbreadths

It weights 400 lb an can be therefore built on a boat, on a wagon, on top of a camel or in a tree

It has more than 2 complete walls

The roof is not made of bundles of straw or sticks that are tied together

The roof is not made of utensils and is useless for any other purpose

It's narrower than 19 x 8 feet

The roof is not made of food

There are more than 3 walls and the structure is solid enough to resist steady wind

The sky and the stars are visible through the roof

The roof is made of *schach*

Thanks to its 4 inches wide wooden planks, the roof provides more shade than sunshine

The structure dynamically draws the eye up to its roof, and the sky beyond

The roof is made of wood

The 8.5 feet height is more than 10 handbreadths and less than 20 cubits



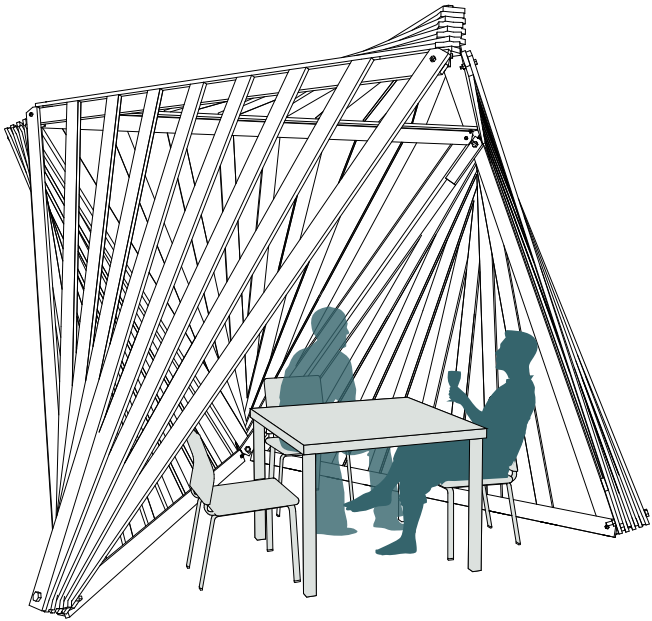

The lattice structure provides shade and is large enough to host a table and few chairs

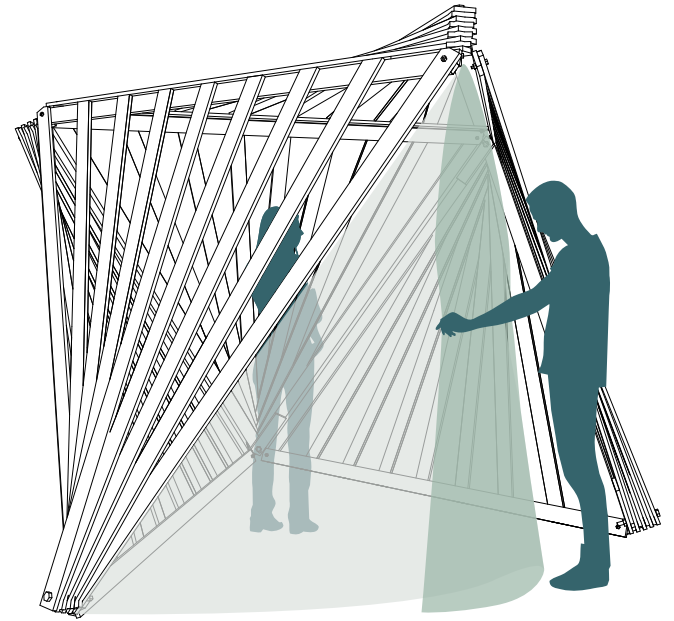

The entrance - one of the two missing triangles - can be equipped with a curtain

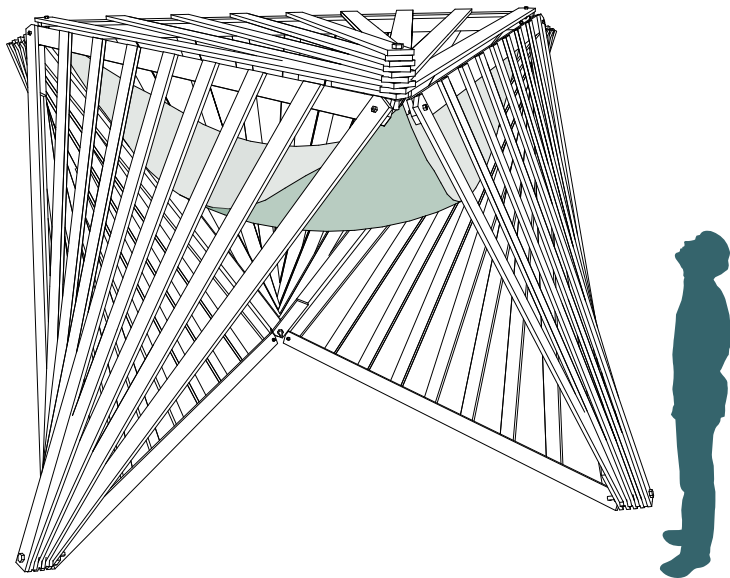

A triangular hammock-like elastic net can be attached to the corners of the roof structure

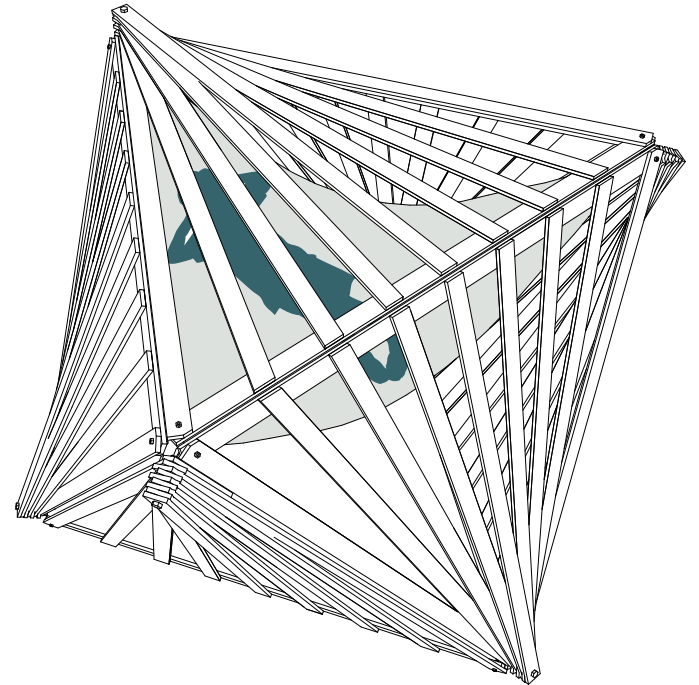

A comfortable surface becomes available to lay down, watch the stars or simply fall asleep

